

FLEX

... EASY UP, EASY DOWN

FLEX folding and swivel tables have a large range of different uses, they are self-explanatory and very easy to handle. Because they are stackable and don't need much space to store, they are the perfect furnishings for flexible room settings, workshops, seminar areas and coworking spaces. The FLEX table range can also be used as a mobile meeting table or as a workstation.

Thanks to optional details such as tabletop connectors, cable management and impact protection edge, the FLEX tables can be individualised as needed. There is a large selection of tabletop sizes and material surfaces to choose from.

FLEX, a particularly attractive and modern addition to your working environment.



bene

INSPIRING OFFICES. SINCE 1790.

A TECHNICAL REQUEST AS A WHITE LABEL ARTICLE ABOUT AXAPTA IS NECESSARY TO ORDER! DATA CURRENTLY AVAILABLE ONLY IN MEDIA BROWSER.

PRODUCT DESCRIPTION – FLEX FOLDING TABLE

This folding table is space-saving, can be folded to 40 cm, it has a mechanical locking system, an anti-shock system (fingers cannot be pinched!), and can be easily moved by one person.

- ❶ **Tabletop:** 19 mm or 25 mm chipboard, melamine
- ❷ **Frame:** powder-coated black
- ❸ **Castors:** black and equipped with brakes
- ❹ **Centre crossbar:** anthracite

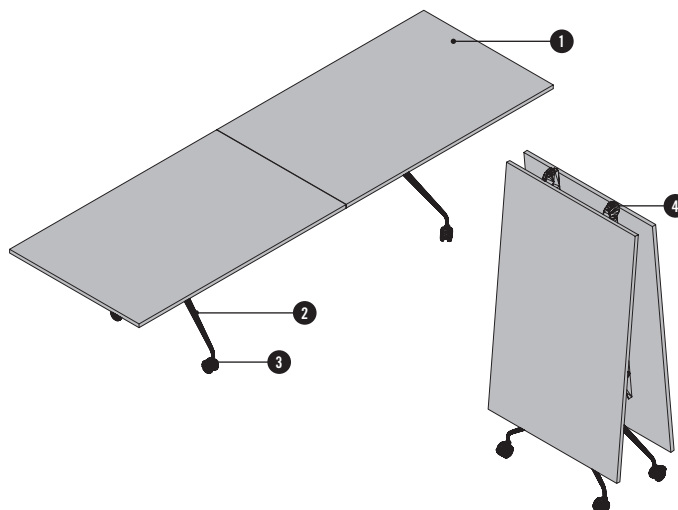

OVERVIEW AND DIMENSIONS

FLEX FOLDING TABLE

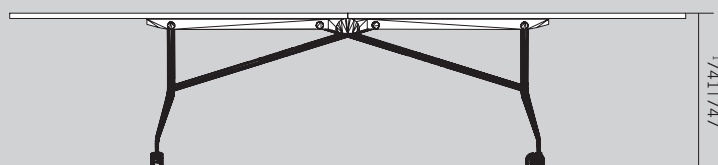
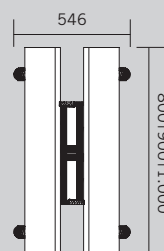
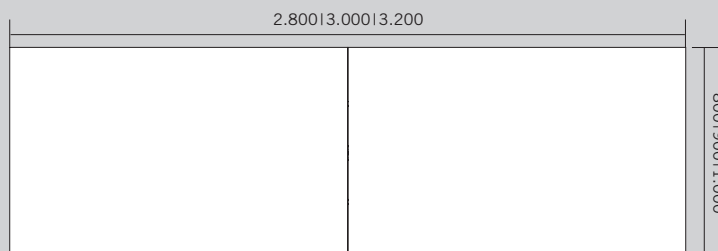

¹ depends on tabletop thickness

Measurements in mm

A TECHNICAL REQUEST AS A WHITE LABEL ARTICLE ABOUT AXAPTA IS NECESSARY TO ORDER! DATA CURRENTLY AVAILABLE ONLY IN MEDIA BROWSER.

PRODUCT DESCRIPTION – FLEX SWIVEL TABLE, SLIM

Tabletop tilts, so it is space-saving and stackable. Unlock it by pushing the two locking levers; ideally suited for office, training and conference rooms, easy for one person to stack and move.

- ❶ **Tabletop:** 19 mm or 25 mm chipboard, melamine
- ❷ **Corners:** cornered or Soft Edge with rounded corner R 50 mm
- ❸ **Frame:** powder coated in white, black or aluminium colour
- ❹ **Castors:** black and equipped with brakes
- ❺ **Centre crossbar:** anthracite

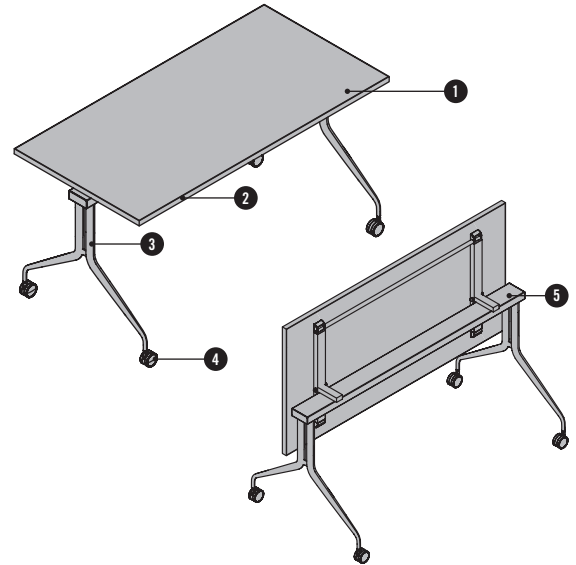

OVERVIEW AND DIMENSIONS

FLEX SWIVEL TABLE, SLIM

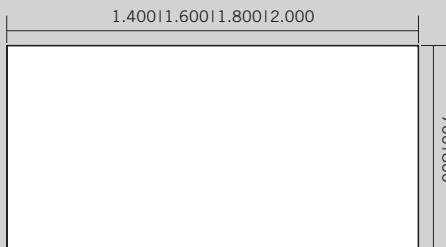

¹ depends on tabletop thickness

Measurements in mm

A TECHNICAL REQUEST AS A WHITE LABEL ARTICLE ABOUT AXAPTA IS NECESSARY TO ORDER! DATA CURRENTLY AVAILABLE ONLY IN MEDIA BROWSER.

PRODUCT DESCRIPTION – FLEX SWIVEL TABLE, BOLD

Tabletop tilts, so it is space-saving and stackable. The tabletop has a practical opening and locking system, ideal for office, training and conference rooms, easy for one person to stack and move.

- ❶ **Tabletop:** 19 mm or 25 mm chipboard, melamine
- ❷ **Corners:** cornered or Soft Edge with rounded corner R 50 mm
- ❸ **Frame:** powder coated in white, black or aluminium colour
- ❹ **Castors:** black and equipped with brakes
- ❺ **Centre crossbar:** anthracite

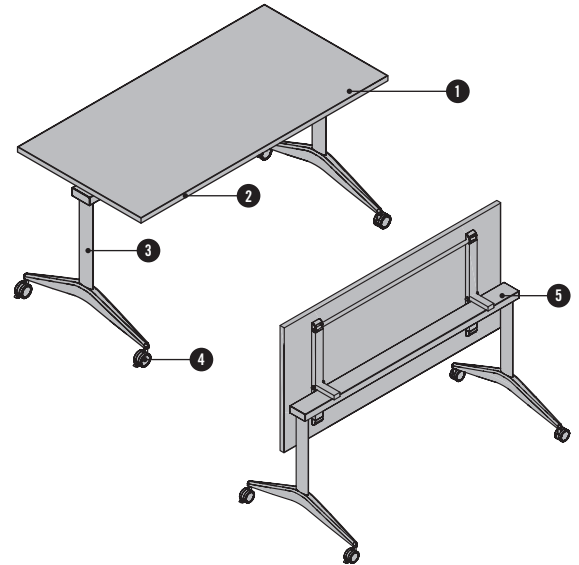

OVERVIEW AND DIMENSIONS

FLEX SWIVEL TABLE, SLIM

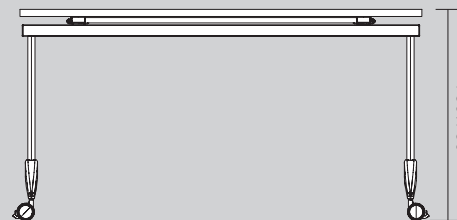
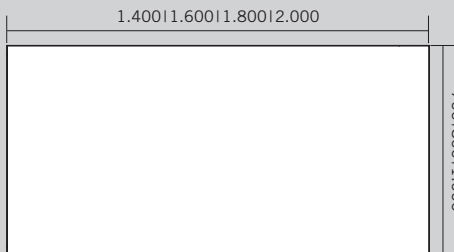

¹ depends on tabletop thickness

Measurements in mm

A TECHNICAL REQUEST AS A WHITE LABEL ARTICLE ABOUT AXAPTA IS NECESSARY TO ORDER! DATA CURRENTLY AVAILABLE ONLY IN MEDIA BROWSER.

OPTIONS FOR FOLDING & SWIVEL TABLES

TABLETOP CONNECTORS

Optionally, two or more tables can be connected at the short end using tabletop connectors. Tabletop connectors available in black.

Two connectors are included in every delivery.

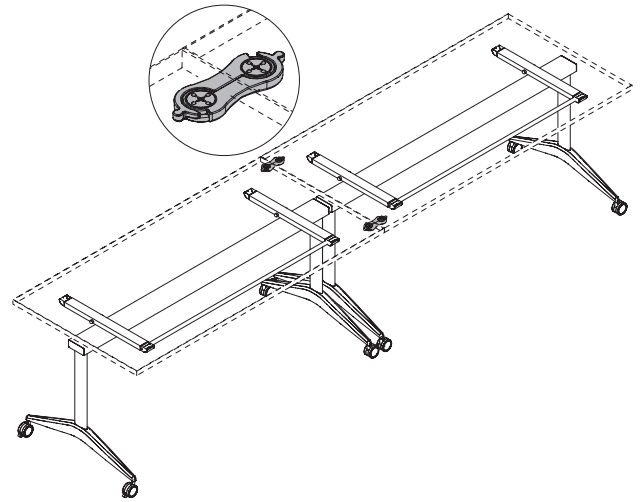

CABLE TRAY

A metal cable tray in black is optionally available for cable management. Dimension: length 500mm

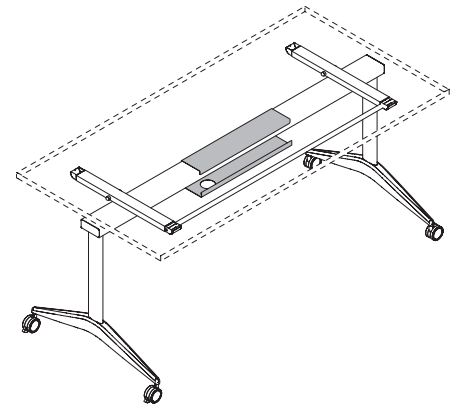

CABLING AND CONNECTIVITY

· Bachmann Coni built-in frame, 3-way, powder-coated

Connection plug board versions

- 3 x power
- 2 x power, 1x USB A/C charger
- 1 x power, 2x RJ45, 1x HDMI

Only available for the swivel tables.

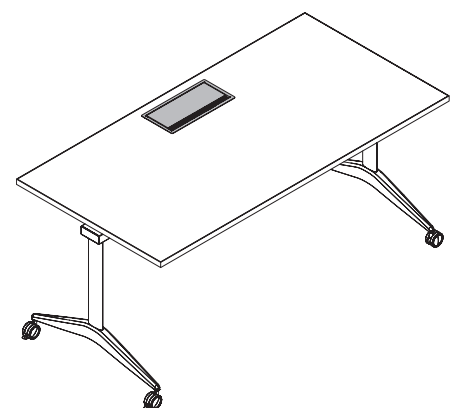

A TECHNICAL REQUEST AS A WHITE LABEL ARTICLE ABOUT AXAPTA IS NECESSARY TO ORDER! DATA CURRENTLY AVAILABLE ONLY IN MEDIA BROWSER.

COLOURS & MATERIALS

MELAMINE: Basic colours



MW white

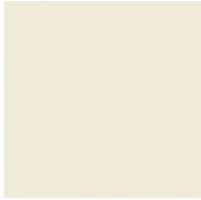

MQ office white

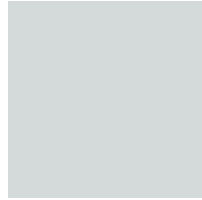

MP platinum



MS slate

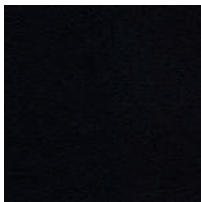

MB basalt

MELAMINE: Additional basic colours



TM clay



MH stone grey



MD urban grey